



**ZUCHELLI**  
**F O R N I**

# FORNI CICLOTERMICI

CYCLOTHERMIC OVENS  
HORNOS CICLOTERMICOS  
FOURS CYCLOTHERMIQUES



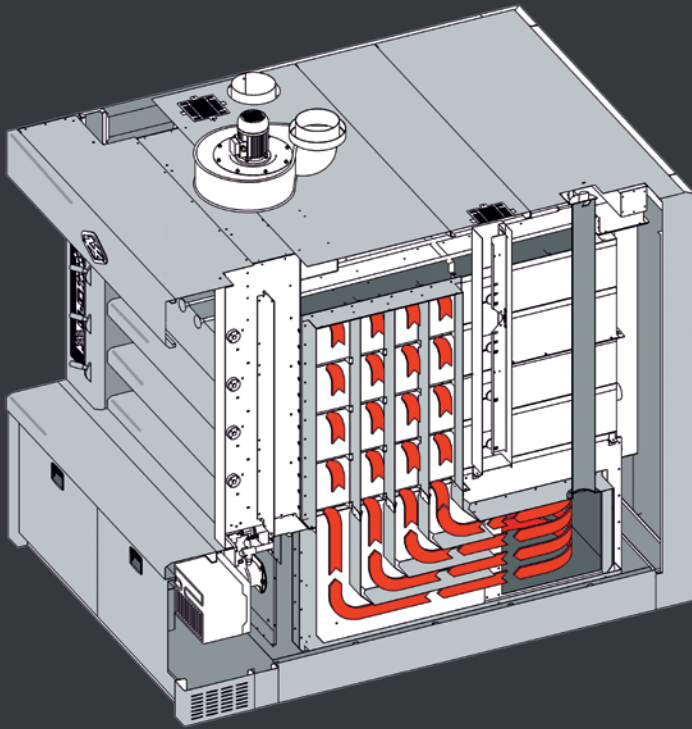

### SEZIONE FORNO CICLOTERMICO

Il sistema di circolazione dell'aria ripartito in 4 zone assicura una migliore omogeneità di cottura.



### SECTION OF CYCLOTHERMIC DECK OVEN

The air circulation system, with 4 different adjustment areas, ensures a better baking evenness.



### SECCION DEL HORNO DE PISOS CICLOTERMICO

El sistema de circulación del aire repartido en 4 zonas de regulación garantiza una mejor homogeneidad de cocción.



### SECTION FOUR CYCLOTHERMIQUE

Le système de circulation de l'air repart en 4 zones de régulation assure une meilleure homogénéité de cuisson.



Portina in vetro temperato con nuovo sistema di apertura leggero nella movimentazione e facilmente smontabile per la pulizia.



Tempered door glass with a new opening system, which is very easy to handle and to disassemble for cleaning operations.



Puerta de vidrio templado con nuevo sistema de abertura, muy manejable y fácilmente desmontable para ser limpiado.



Porte en verre trempé avec le nouveau système d'ouverture d'un maniement aisé et facilement démontable pour le nettoyage du four.



Pannello comandi disponibile in due versioni: elettromeccanico e digitale.



Control panel available in two versions: electromechanical and digital.



Panel de control disponible en dos versiones: electromecánico y digital.



Tableau commandes disponible en deux modèles: électromécanique et digital.



SCT 3



#### CICLOTHERMIC DECK OVEN

- Oven with 3 or 4 static baking chambers
- Combustion oven for gas or gasoil feeding
- Baking plates made of refractory fiber glass
- Satin finish stainless steel oven front, external panelling in prepainted sheet iron
- Electromechanical or digital control panel
- Independent steam generator with direct control

#### Optionals:

- Lateral panelling in stainless steel
- Upper deck with working (internal) height 23 cm



#### HORNOS CICLOTÉRMICOS

- Horno de 3 o 4 pisos fijos
- Horno de combustión con alimentación gas o gasóleo
- Soleras refractarias en fibra de vidrio
- Fachada de acero inox satinado, paneles exteriores de chapa pintada al horno
- Cuadro de mandos electromecánico o digital
- Vaporizadores independientes mandados directamente

#### Opciones:

- Paneles exteriores de acero inox
- Piso superior de altura útil (interna) 23 cm



#### FORNI CICLOTÉRMICI

- Forno a 3 o 4 piani fissi
- Forno a combustibile, alimentazione bruciatore gas o gasolio
- Piani cottura refrattari in fibra di vetro
- Facciata acciaio inox satinato, pannellatura esterna in lamiera preverniciata
- Pannello comandi elettromeccanico o digitale
- Vaporiere indipendenti a comando diretto

#### Optionals:

- Pannellatura esterna acciaio inox
- Camera superiore con altezza utile interna 23 cm



SCT 1



#### FOURS CYCLOTHERMIQUES

- Fours à soles fixes de 3 ou 4 chambres
- Four à combustion, alimentation brûleur gaz ou mazout
- Dalles de cuisson réfractaires en fibre de verre
- Façade en acier inox satiné, revêtement en tôle prévernée
- Tableau de commandes électromécanique ou digital
- Appareils à buée indépendants à commande directe

#### Option:

- Revêtement en acier inox
- Étage supérieur avec hauteur utile 23 cm



SCT 2

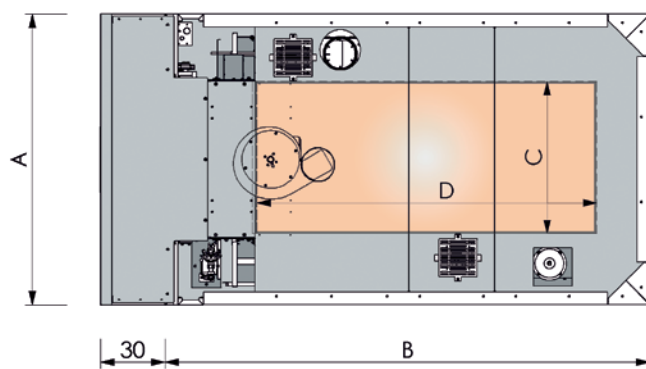
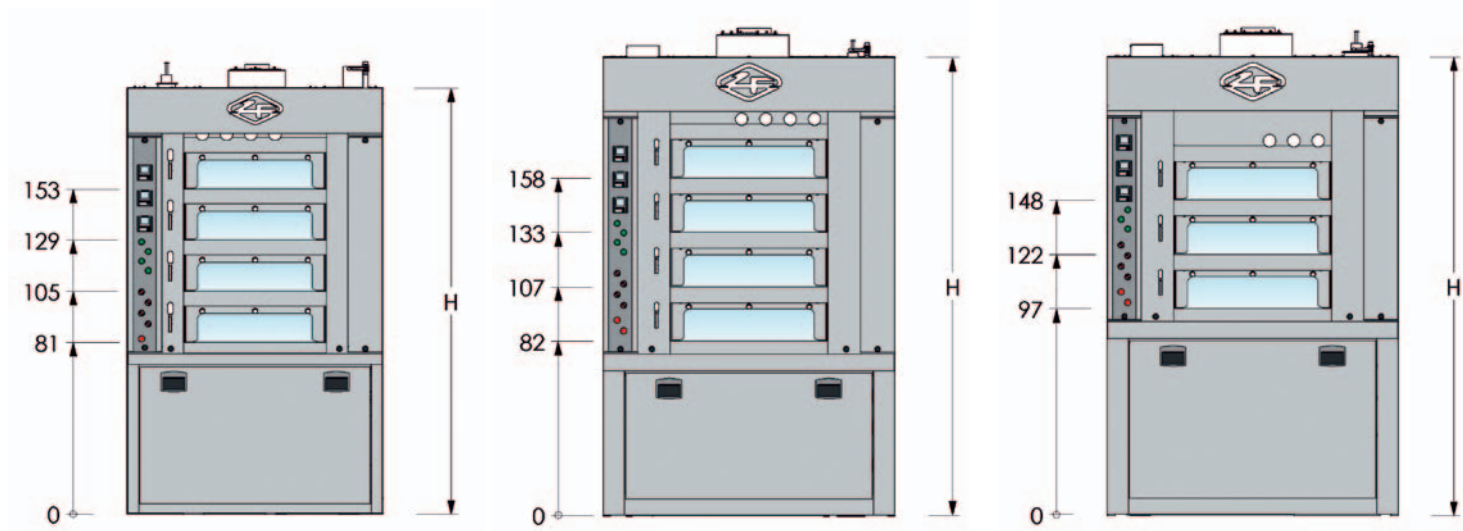

Forno Ciclotermico CT  
Cyclothermic Oven CT  
Horno Ciclotermico CT  
Four Cyclothermique CT

Modello Model Modelo Modele	Dimensioni camere Baking deck dimensions Dimensiones camaras Dimensions des étages		Superf. Cottura Baking surface Superf.coccion Surface cuisson	Produz. Oraria Hourly output Produc. por hora Rend. horaire	Dimensioni est. External dimensions Dimensiones exteriores Dimensions extérieures			Peso Weight Peso Poids	Potenza termica Thermal power Potencialidad termica Puissance thermique	Potenza elettrica Electric power Potencialidad electrica Puissance electricque
	C	D			A	B	H			
	cm	cm	m <sup>2</sup>	kg	cm	cm	cm	kg	kcal	kw
<b>CT7 4C/3,7</b>	66	139	3,7	37	120	221	200	1350	29.000	1,0
<b>CT9 4C/5,4</b>	90	139	5,4	54	146	261	200	1600	42.000	1,0

Forno Ciclotermico SCT1 - Cyclothermic Oven SCT1 - Horno Ciclotermico SCT1 - Four Cyclothermique SCT1

Modello Model Modelo Modele	Dimensioni camere Baking deck dimensions Dimensiones camaras Dimensions des étages		Superf. Cottura Baking surface Superf.coccion Surface cuisson	Produz. Oraria Hourly output Produc. por hora Rend. horaire	Dimensioni est. External dimensions Dimensiones exteriores Dimensions extérieures			Peso Weight Peso Poids	Potenza termica Thermal power Potencialidad termica Puissance thermique	Potenza elettrica Electric power Potencialidad electrica Puissance electricque
	C	D			A	B	H			
	cm	cm	m <sup>2</sup>	kg	cm	cm	cm	kg	kcal	kw
<b>SCT1 3C/4,2</b>	72	200	4,2	42	137	268	215	2050	30.000	1,5
<b>SCT1 4C/4,5</b>	72	160	4,5	45	137	228	215	1950	32.000	1,5
<b>SCT1 4C/5,6</b>	72	200	5,6	56	137	268	215	2250	40.000	1,5

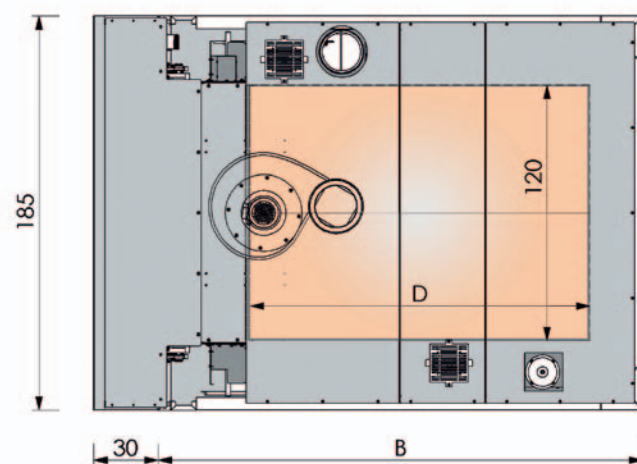
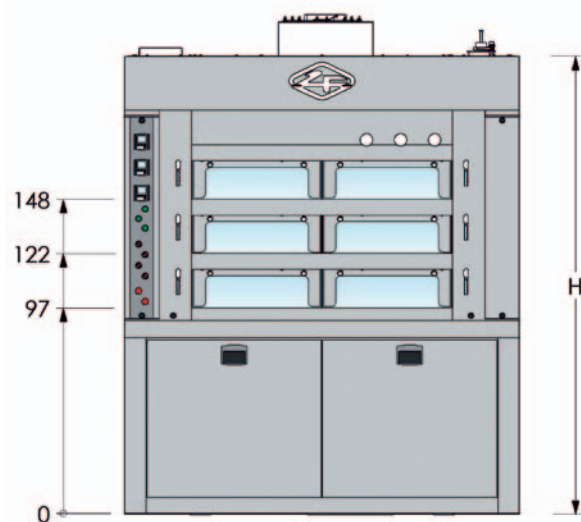
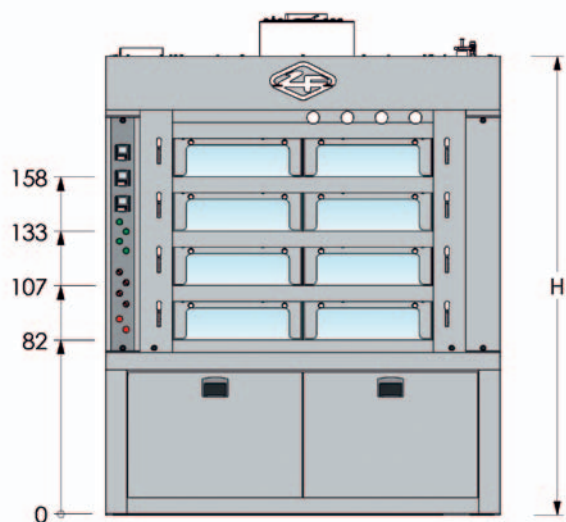

**Forno Ciclotermico SCT2**  
 Cyclothermic Oven SCT2  
 Horno Ciclotermico SCT2  
 Four Cyclothermique SCT2

Modello Model Modelo Modele	Dimensioni camere Baking deck dimensions Dimensiones camaras Dimensions des étages		Superf. Cottura Baking surface Superf.coccion Surface cuisson	Produz. Oraria Hourly output Produc. por hora Rend. horaire	Dimensioni est. External dimensions Dimensiones exteriores Dimensions extérieures		Peso Weight Peso Poids	Potenza termica Thermal power Potencialidad termica Puissance thermique	Potenza elettrica Electric power Potencialidad electrica Puissance electricque
	D	B			H				
	cm	mq	kg	cm	cm	kg	kcal	kw	
<b>SCT2 3C/6</b>	160	5,8	58	228	215	2460	42.000	2,5	
<b>SCT2 3C/7</b>	200	7,2	72	268	215	2860	49.000	2,5	
<b>SCT2 4C/8</b>	160	7,7	77	228	215	2750	56.000	2,5	
<b>SCT2 4C/10</b>	200	10	100	268	215	3250	70.000	3	
<b>SCT2 4C/12</b>	250	12	120	318	215	3800	85.000	3	

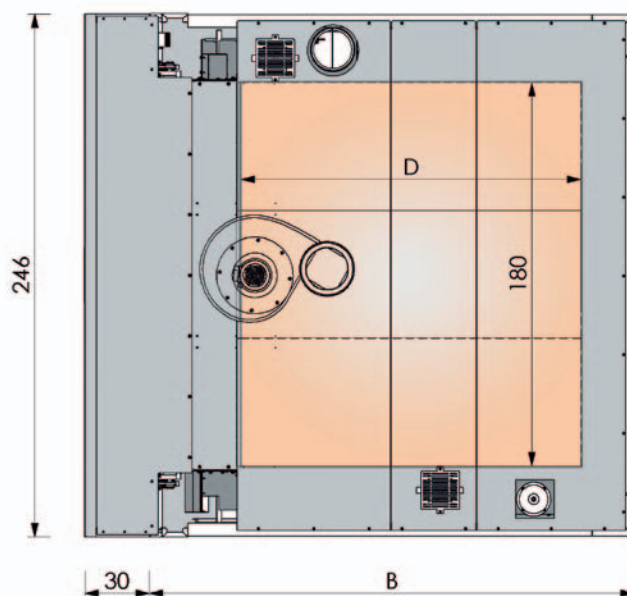
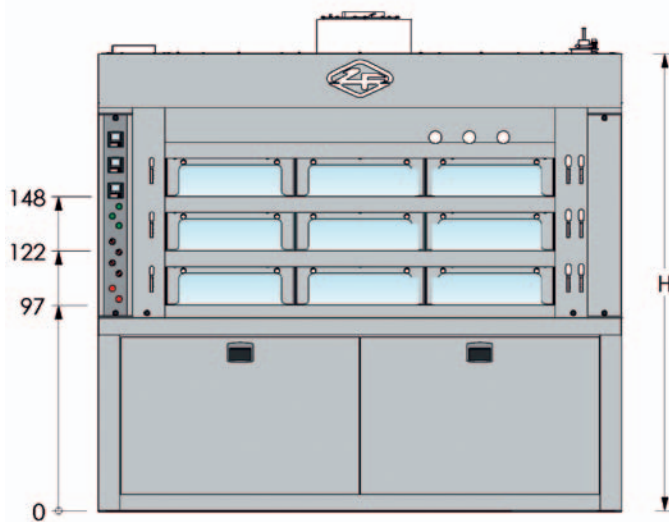
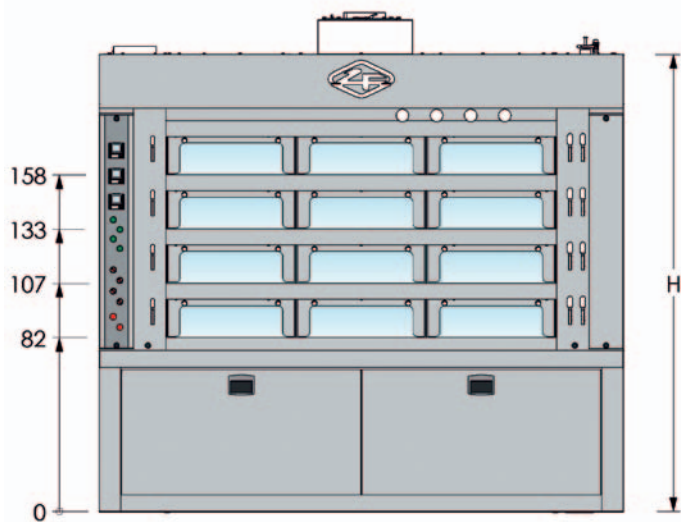

Forno Ciclotermico SCT3  
 Cyclothermic Oven SCT3  
 Horno Ciclotermico SCT3  
 Four Cyclothermique SCT3

Modello Model Modelo Modele	Dimensioni camere Baking deck dimensions Dimensiones camaras Dimensions des étages		Superf. Cottura Baking surface Superf.coccion Surface cuisson	Produz. Oraria Hourly output Produc. por hora Rend. horaire	Dimensioni est. External dimensions Dimensiones exteriores Dimensions extérieures		Peso Weight Peso Poids	Potenza termica Thermal power Potencialidad termica Puissance thermique	Potenza elettrica Electric power Potencialidad electrica Puissance electrica
	D	B			H				
	cm	mq	kg	cm	cm	kg	kcal	kw	
<b>SCT3 3C/9</b>	160	8,6	86	228	215	2950	63.000	3	
<b>SCT3 3C/11</b>	200	10,8	108	268	215	3380	77.000	3	
<b>SCT3 3C/13</b>	250	13,5	135	318	215	3910	90.000	3	
<b>SCT3 4C/11</b>	160	11,5	115	228	215	3350	77.000	3	
<b>SCT3 4C/14</b>	200	14,4	144	268	215	3850	95.000	3	
<b>SCT3 4C/18</b>	250	18,0	180	318	215	4350	120.000	5	



### CELLE PER FORNI A PIANI FISSI

- Struttura portante in acciaio inox e rivestimento esterno in doppia parete metallica con intercapedine isolante. Con o senza basamento.
- Il calore e l'umidità sono erogati dal forno oppure indipendentemente con un apposito gruppo di riscaldamento dotato di ventilatore e resistenze per garantire un'uniformità di lievitazione su tutti i prodotti.



### CAMARAS DE FERMENTACION PARA HORNO DE PISOS FIJOS

- Estructura portante de acero inoxidable, revestimiento exterior con doble pared metálica con espacio intermedio aislante. Con o sin suelo.
- El calor y la humedad son producidos directamente del horno o independientemente por un expreso grupo de calefacción, dotado de ventilador y resistencias, para garantizar uniformidad de fermentación en todos los productos.



### PROOFERS FOR DECK OVENS

- Supporting structure made of stainless steel, double external metal covering with isolated hollow space. With or without floor.
- Heat and humidity are provided by the oven or independently through a special heating group equipped with ventilator and heating elements in order to grant an even leavening of all products.



### CHAMBRES DE FERMENTATION POUR FOURS SOLES FIXES

- Structure en acier inox, revêtement extérieur avec double paroi métallique avec un espace d'isolation. Avec ou sans sol.
- La chaleur et l'humidité sont distribuées par le four ou de façon indépendante par un groupe de chauffage équipé des ventilateurs et résistances afin de garantir une fermentation uniforme à tous les produits.

Modello Model Modelo Modele	Dimensioni est. External dimensions Dimensiones exteriores Dimensions extérieures			Potenzialità elettrica Electric power Potencialidad eléctrica Puissance électrique
	A	B	H	
	cm	cm	cm	
<b>1P LU.160</b>	100	242	215	4
<b>2P LU.160</b>	202	242	215	6
<b>1P LU.200</b>	100	282	215	4
<b>2P LU.200</b>	202	282	215	6
<b>1P LU.250</b>	100	332	215	4
<b>2P LU.250</b>	202	332	215	8

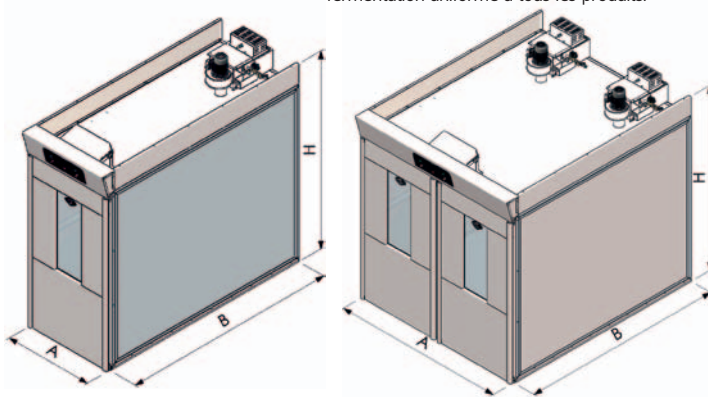

### PALA INTEGRATA MANUALE

Pala per l'infornamento e lo sfornamento con sistema di salita e discesa assistito. Completa di telaio a spostamento laterale manuale. Su richiesta è possibile scegliere il lato operatore della pala (carico/scarico del telaio a destra o a sinistra).



### CARGADOR INTEGRADO MANUAL

Cargador integrado para hornear y sacar el producto, con sistema asistido de subida y bajada. Completo de bastidor que se mueve a mano lateralmente. Previa solicitud es posible elegir el lado trabajador del cargador (carga / descarga del bastidor a la derecha o a la izquierda).



### INTEGRATE MANUAL LOADER

Integrated loader for loading and unloading, with assisted rising / descending system. Supplied complete with loader that manually moves sideways. On request it is possible to choose the operating side of the integrated loader (loading/unloading of loader from the right or left side).



### ÉLÉVATEUR INTÉGRÉ MANUEL

Élévateur pour l'enfournement et le défournement avec système de montée et descente manuelle. Complet d'enfourneur, déplacement latéral manuel. Sur demande il est possible de choisir le côté opérateur de l'élévateur (chargement/déchargement de l'enfourneur à droite ou à gauche).

Modello Model Modelo Modele	Profondità camera Deck depth Profundidad cámara Profondeur étage	Dimensioni est. External dimensions Dimensiones exteriores Dimensions extérieures			Peso Weight Peso Poids
		A	B	H	
		cm	cm	cm	
<b>EM07</b>	per forni modello EL.07 for ovens model EL.07 para horno modelo EL.07 pour fours modele EL.07 L=160 L=200	164	207 207	249	260
<b>EM12</b>	per forni modello EL.12 for ovens model EL.12 para horno modelo EL.12 pour fours modele EL.12 L=120 L=160 L=200 L=250	212	187 207 207 257	249	285
<b>EM18</b>	per forni modello EL.18 for ovens model EL.18 para horno modelo EL.18 pour fours modele EL.18 L=120 L=160 L=200 L=250	273	187 207 207 257	249	320

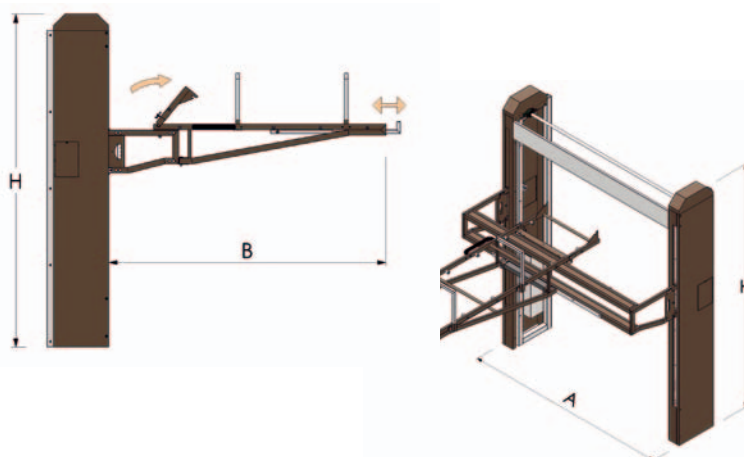



**ZUCHELLI**  
**F O R N I**

Zucchelli Forni S.p.a.  
37060 - Trevenzuolo (Vr) - Italy  
Zona Artigiana S. Pierino  
Tel. 045 6680068 r.a. - Fax 045 7350285

[www.zucchelliforni.it](http://www.zucchelliforni.it)  
e-mail: [info@zucchelliforni.it](mailto:info@zucchelliforni.it)